

0.75 Kw

50/60Hz
380V



Modello automatico adatto ad un utilizzo generico e a pane compatto o con crosta di media durezza. Disponibile in due dimensioni di taglio (420 e 520mm). Taglierina adatta a piccoli-medi laboratori. Può lavorare in modalità di taglio singolo e di taglio continuo. Velocità di taglio regolabile e coperchio di sicurezza in acciaio con chiusura ed apertura automatici

Automatic model suitable for general use, for compact bread or for bread with a medium hardness baked crust. It is available in two cutting sizes (420 and 520 mm). This slicer is suitable for small-medium sized laboratories. It can work in single and continuous cutting mode. It features adjustable cutting speeds and a steel safety top with automatic closing and opening

Modelo automático también apto para un uso genérico y para pan compacto con corteza de dureza mediana. Está disponible en dos dimensiones de corte (420 y 520mm). Cortadora apta para talleres pequeños y medianos. Puede funcionar en modalidad de corte simple y de corte continuo. Velocidad de corte ajustable y tapa de seguridad de acero con cierre y apertura automáticos

Modèle automatique idéal pour une exploitation générique et pour la coupe de pain compact ou avec croûte moyennement dure. Disponible en deux largeurs de coupe (420 et 520 mm). Trancheuse idéale pour

petits et moyens laboratoires. La coupure peut être effectuée en continu ou singulièrement. Vitesse de coupe réglable et couvercle de sécurité en acier à fermeture et ouverture automatique

Модель автоматическая для общего использования, а также для нарезки хлеба с более плотным мякишем или с коркой средней твёрдости. Доступны версии с двумя размерами отверстия нарезки (420 и 520 мм). Модель подходит для использования на небольших хлебокондитерских предприятиях. Режимы единичной и непрерывной нарезки. Скорость регулируется и стальная защитная крышка с автоматическими закрытием и открытием

Automatisches Tischmodell für die allgemeine Verwendung, für kompaktes Brot oder für Brot von mittlerer Härte. In zwei Schnittgrößen (420 und 520 mm) erhältlich. Aufgrund seiner Kompaktheit ist das kleinste Modell (420mm) auch für den rückwärtigen Tisch von Geschäften, für kleine-mittelgroße Labors und Restaurants geeignet. Das Modell kann im Einzelschneid- und kontinuierlichem Schneidmodus arbeiten. Einstellbare Schnittgeschwindigkeit und Sicherheitsabdeckung aus Stahl mit automatischer Schließung und Öffnung

| | CP42S / CP52S |
|---|--|
| Modello - Model | Automatica su ruote / Automatic free standing type |
| Carico - Loading | Laterale / Lateral |
| Lunghezza nominale taglio - Nominal width cut | 420 - 520 mm |
| Dimensione max. pane mm - Loaf max. dimensions mm | 400/500 x 230 x 180h |
| Passo lame - Blade pitches | Scelta da 9 a 20 mm / Available from 9 to 20 mm |

✗ Standard ○ Optional

Specifiche tecniche / Technical specifications



| | G42 | C42-C52 | CP42-CP52 | C42S-C52S | CP42S-CP52S | ST42 | SA35-SA50 | MI52 | MR52 | MAC100 | BM11 |
|--|-----|---------|-----------|-----------|-------------|------|-----------|------|------|--------|------|
| Struttura in acciaio verniciata Steel powder painted body | ✗ | ✗ | ✗ | ✗ | ✗ | ✗ | ✗ | ✗ | ✗ | | |
| Modello da tavolo Bench model | ✗ | ✗ | ✗ | | | | | | | | |
| Modello con ruote Models on wheels | | | | | ✗ | ✗ | ✗ | ✗ | ✗ | | |
| Manuale Manual | ✗ | ✗ | ✗ | ✗ | | | | | | | |
| Automatica Automatic | | | ✗ | | ✗ | ✗ | ✗ | ✗ | ✗ | | |
| Automatica a ciclo singolo e continuo Automatic single and continuous mode | | | ✗ | | ✗ | | | | | | |
| Automatica a ciclo continuo Automatic continuous cut | | | | | | | | ✗ | ✗ | | |
| Automatica con 4 modalità di taglio Automatic with 4 cutting modes | | | | | | | ✗ | | | | |
| Carico frontale Front loading | ✗ | ✗ | ✗ | | | ✗ | ✗ | | | | |
| Carico laterale/posteriore Lateral/rear loading | | | | ✗ | ✗ | | | ✗ | ✗ | | |
| Passo fetta variabile Adjustable pitch | | | | | | | ✗ | | | | |
| Telaio coltelli intercambiabile (brevetto) Interchangeable blade cartridge (patent) | | | | | | | | | ✗ | | |
| Regolazione elettrica tappeto superiore Electrically adjustable upper conveyor | | | | | | | | ✗ | ✗ | | |
| Regolazione velocità con inverter Speed regulation with inverter | | | | | | | | ✗ | ✗ | | |
| Velocità tappeto e telai indipendenti Independent speed of conveyor and cutting frames | | | | | | | | ✗ | ✗ | | |
| Insufflatore Bag blower | | | | ○ | ○ | | | | | | |
| Base con ruote Base with wheels | ○ | ○ | ○ | | | | | | | | |
| Oliatore Oiling system | ○ | ○ | ○ | ○ | ○ | ○ | ○ | ○ | ○ | | |
| Struttura in alluminio e inox Aluminum & s/steel structure | | | | | | | | | | ✗ | ✗ |
| Kit mollica Fresh bread knife kit | | | | | | | | | | | ○ |
| Piedini inox S/steel legs | | | | | | | | | | | ○ |



Dimensioni / Dimensions



Peso netto / Net weight

G42

C42/C52

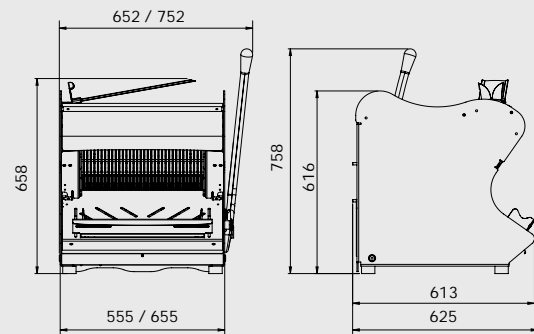
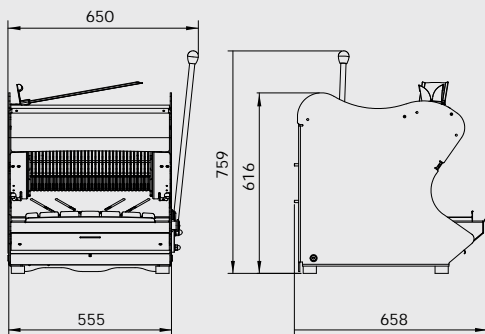

98 Kg.

101 / 107 Kg.

CP42/CP52

BASE

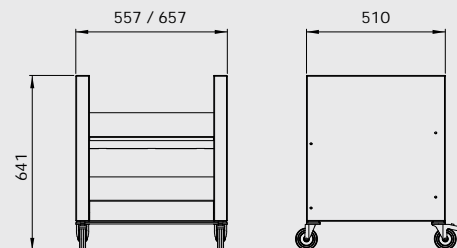
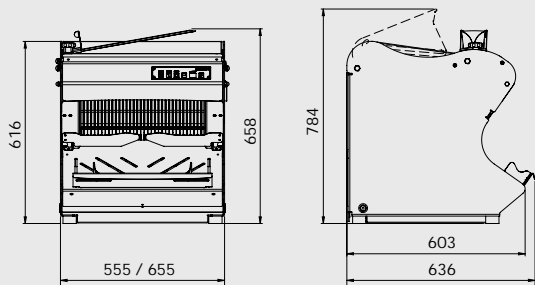

101 / 107 Kg.

28 / 30 Kg.

C42S/C52S

CP42S/CP52S

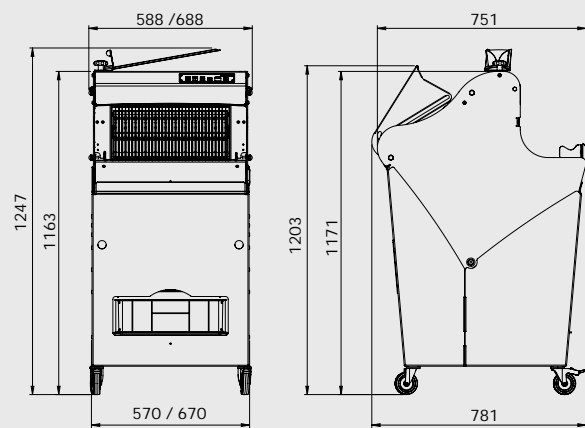
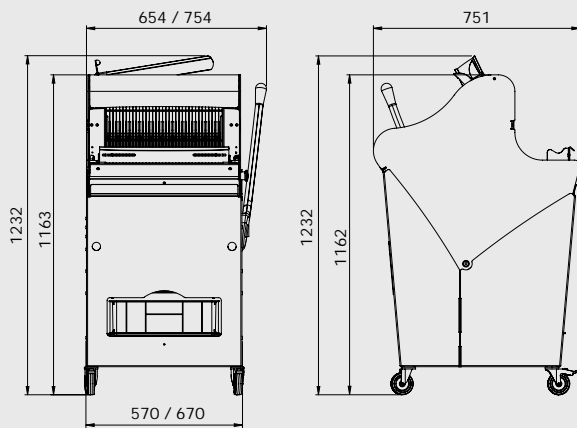

135 - 142 Kg.

135 - 142 Kg.