

0.55 Kw

50/60Hz  
400V-3 Ph

Sfogliatrice da tavolo con piani in acciaio. Inversione del ciclo di lavoro con joy-stick. Griglie di protezione con micro di sicurezza. Adatta a qualsiasi tipo di pasta

**Table-top sheeter with steel tables. Work cycle inversion with joy-stick. Protection grids with safety microswitch. Suitable for any type of dough**

Laminadora para banco con planos de acero. Inversión del ciclo de trabajo con joy-stick. Rejillas de protección con microinterruptor de seguridad. Apta para cualquier tipo de masa

Laminoir à table avec plan de travail en acier. Inversion du cycle de travail par joystick. Grillages de protection doués de microinterrupteur de sécurité. Idéale pour tous les types de pâte

Настольная тестораскаточная машина с рабочими столами из нержавеющей стали. Реверсирование направления движения выполняется посредством джойстика. Защитные покрытия (решётки) оборудованы микровыключателем безопасности. Предназначена для раскатки любого вида теста

Tischausrollmaschine mit Edelstahlböden. Umkehr des Arbeitszyklus mit Joystick. Schutzgitter mit Sicherheitsschalter. Für alle Teigarten geeignet

	S5BM
Larghezza cilindri - Roller width	500 mm



## Specifiche tecniche / Technical specifications

× Standard ○ Optional

	RV50	SHV	S5BM	SH50B-SH60B	SH500-SH600	SH6002	R62   R62-T	R65   R65-T	R65S   R65S-T	R65A   R65A-T	R65AX   R65AX-T	EUROSTAR
Inversione ciclo con joystick <b>Joystick cycle reversal</b>			×	×	×							
Inversione ciclo con barra <b>Bar cycle reversal</b>						×						
Inversione ciclo con impulso elettrico <b>Electric cycle reversal</b>							×	×	×			
Inversione ciclo a pedale <b>Pedal cycle reversal</b>					○		○	○				
Tavoli removibili <b>Removable tables</b>						×	× <sup>(1)</sup>	× <sup>(1)</sup>	× <sup>(1)</sup>	× <sup>(1)</sup>	× <sup>(1)</sup>	× <sup>(1)</sup>
Sfarinatore automatico <b>Automatic flour duster</b>								○	○	○	×	×
Avvolgitore automatico <b>Automatic reeler</b>								○ <sup>(2)</sup>	○	○	×	×
Regolazione velocità con Inverter <b>Inverter speed regulation</b>		×		○	○	○	○ <sup>(3)</sup>	○ <sup>(3)</sup>	×	×	×	×
Unità di taglio <b>Cutting unit</b>						○	○ <sup>(3)</sup>	○ <sup>(3)</sup>	○ <sup>(3)</sup>	○ <sup>(3)</sup>	○ <sup>(3)</sup>	○
Carrello <b>Trolley</b>				○								
Ripiano intermedio con bacinelle <b>Shelf with basins</b>							○ <sup>(1)</sup>	○ <sup>(1)</sup>	○ <sup>(1)</sup>	○ <sup>(1)</sup>		
Kit 2 tavoli intermedi con bacinelle <b>Kit 2 intermediate shelves with basins</b>											○	

(1) Con alcune limitazioni / **With some limitations** - (2) Solo modelli con inverter / **Inverter models only** - (3) Standard su versioni T / **Standard on T version**



RV50

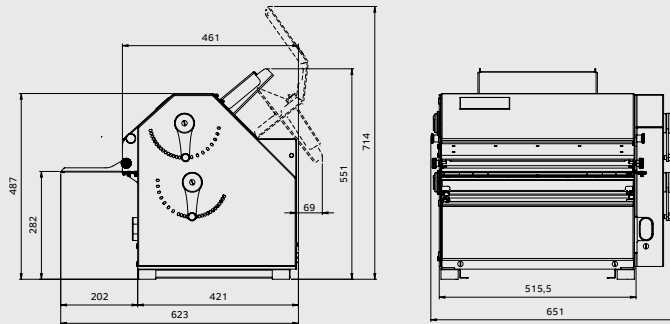

KG 85 Kg

S5BM

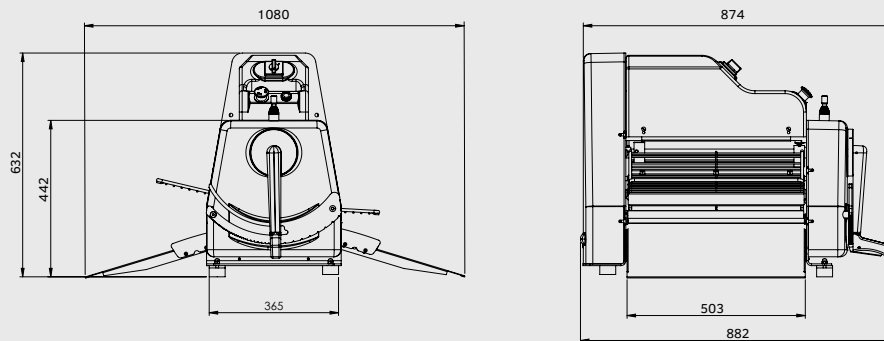

KG 81 Kg

R50B

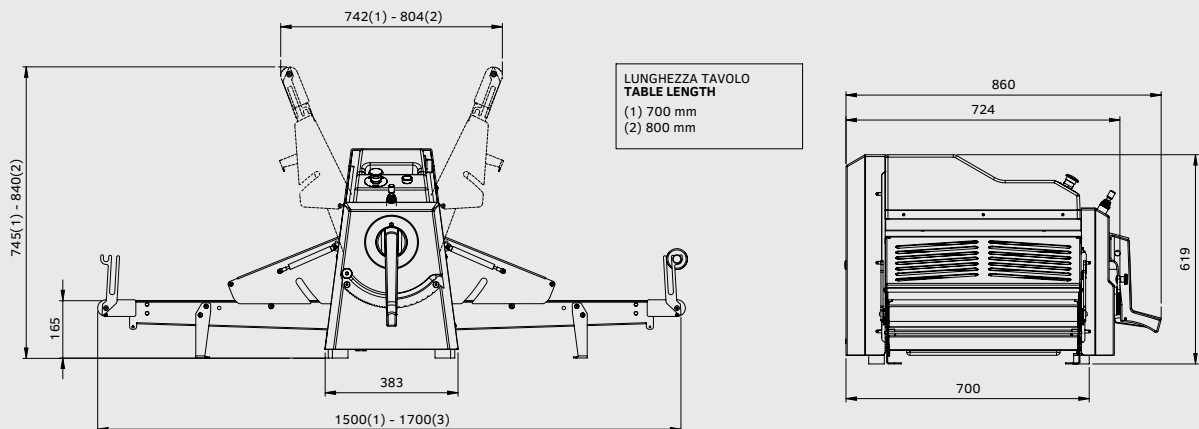

KG 91 ÷ 120 Kg