0.75 Kw
(R62)1.10 Kw
(R65)50/60Hz
400V-3 Ph

Sfogliatrice manuale su base con ruote disponibile anche in versione con sistema di taglio incorporato (R62-T, R65-T). Tavoli ripiegabili ed estraibili. Inversione del ciclo di lavoro con tasti ad impulso elettrico e pedaliera. Il sistema di regolazione dei cilindri (brevetto Rollmatic), permette un movimento fluido, senza sforzo e con precisione micrometrica. Protezioni dei cilindri con micro di sicurezza e molla a gas. Sistema rapido di tensionatura e sgancio dei tappeti. Raschiatori con rilascio rapido QR (Quick Release), brevetto Rollmatic. Cassetto farina con micro di sicurezza

Manual sheeter on base with castors also available with in-built cutting system (R62-T, R65-T). Folding and extractable tables. Work cycle inversion with electric impulse keys and foot control. The cylinder adjustment system (patented by Rollmatic), allows a seamless and effortless movement along with micrometric precision. Cylinder guards with safety microswitch and gas spring. Quick belt tensioning and release system. QR (Quick Release) scrapers, patented by Rollmatic. Flour drawer with safety microswitch

Laminadora manual sobre base con ruedas disponible también en versión con sistema de corte incorporado (R62-T, R65-T). Bancos retráctiles y extraíbles. Inversión del ciclo de trabajo con teclas de impulso eléctrico y pedales. El sistema de regulación de los cilindros (patente Rollmatic) permite un movimiento fluido, sin esfuerzo y con precisión micrométrica. Protecciones de los cilindros con microinterruptor de seguridad y muelle de gas. Sistema rápido de tensado y desenganche de las cintas. Rasquetas con liberación rápida QR (Quick Release), patente Rollmatic. Cajón de harina con microinterruptor de seguridad

Laminoir manuel avec base montée sur roues, disponible aussi dans la version avec système de coupe intégré (R62-T, R65-T). Tables pliables et amovibles. Inversion du cycle de travail par touches à impulsion électrique et pédalier. Le

système de réglage des cylindres (brevetés par Rollmatic) permet un mouvement fluide, sans effort et d'une précision micrométrique. Protections des cylindres par microinterrupteur de sécurité et ressort à gaz. Système rapide de mise en tension et de déclenchement des tapis. Racleurs avec système de déclenchement rapide QR (Quick Release) breveté par Rollmatic. Tiroir de récolte de la farine avec microinterrupteur de sécurité

Ручная тестораскаточная машина с основой на колёсах, доступна в версии со встроенной системой нарезки (R62-T, R65-T). Складные и съёмные рабочие столы. Реверсирование направления движения посредством кнопок с электрическим импульсом и педали. Система регуляции цилиндров (патент Rollmatic), обеспечивающая плавное движение и микрометрическую точность. Защитные покрытия цилиндров оборудованы микровыключателем безопасности и газовой пружиной. Быстрая система натяжения и открепления лент. Скребки с быстрой системой открепления QR (Quick Release), патент Rollmatic. Ящик для сбора муки оборудован микровыключателем безопасности

Manuelle Ausrollmaschine auf einer Basis mit Rollen, auch in der Ausführung mit eingebautem Schneidsystem (R62-T, R65-T) erhältlich. Kippbare und herausziehbare Tische. Umkehr des Arbeitszyklus mit Tasten mit elektrischem Impuls und Fußhebel. Das Einstellungssystem der Zylinder (Rollmatic-Patent) erlaubt eine fließende Bewegung, ohne Anstrengung und mit mikrometrischer Präzision. Schutz der Walzen mit Sicherheitsschalter und Gasfeder. Schnellspannsystem und Schnellfreigabesystem der Bänder. Schaber mit Schnellspanner QR (Quick Release), Rollmatic-Patent. Mehlfach mit Sicherheitsschalter

	R62 - R62-T	R65 - R65-T
Larghezza cilindri - Roller width	600 mm	650 mm
Lunghezza tavolo - Table length	1000*-1200-1300-1400 mm	1200**-1400-1600-1800 mm

(*) solo per modello R62 / R62 only - (**) solo per modello R65 / R65 only



Specifiche tecniche / Technical specifications

× Standard ○ Optional

	RV50	SHV	S5BM	SH50B-SH60B	SH500-SH600	SH6002	R62 \ R62-T	R65 \ R65-T	R65S \ R65S-T	R65A \ R65A-T	R65AX \ R65AX-T	EUROSTAR
Inversione ciclo con joystick Joystick cycle reversal			×	×	×							
Inversione ciclo con barra Bar cycle reversal						×						
Inversione ciclo con impulso elettrico Electric cycle reversal							×	×	×			
Inversione ciclo a pedale Pedal cycle reversal					○		○	○				
Tavoli removibili Removable tables						×	× ⁽¹⁾	× ⁽¹⁾	× ⁽¹⁾	× ⁽¹⁾	× ⁽¹⁾	× ⁽¹⁾
Sfarinatore automatico Automatic flour duster								○	○	○	×	×
Avvolgitore automatico Automatic reeler								○ ⁽²⁾	○	○	×	×
Regolazione velocità con Inverter Inverter speed regulation		×		○	○	○	○ ⁽³⁾	○ ⁽³⁾	×	×	×	×
Unità di taglio Cutting unit						○	○ ⁽³⁾	○ ⁽³⁾	○ ⁽³⁾	○ ⁽³⁾	○ ⁽³⁾	○
Carrello Trolley				○								
Ripiano intermedio con bacinelle Shelf with basins							○ ⁽¹⁾	○ ⁽¹⁾	○ ⁽¹⁾	○ ⁽¹⁾		
Kit 2 tavoli intermedi con bacinelle Kit 2 intermediate shelves with basins											○	

(1) Con alcune limitazioni / **With some limitations** - (2) Solo modelli con inverter / **Inverter models only** - (3) Standard su versioni T / **Standard on T version**

Dimensioni / Dimensions

KG Peso netto / Net weight

R65

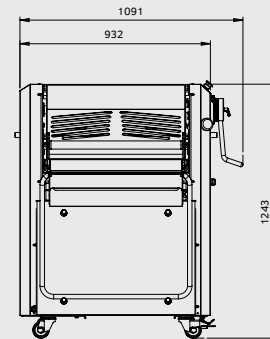
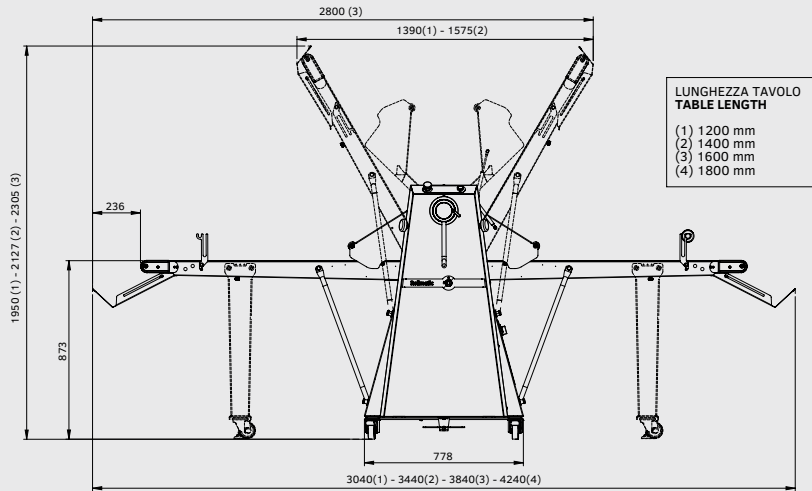

KG 232 Kg

R65-T

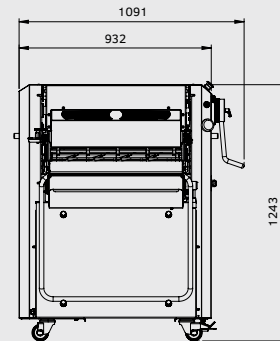
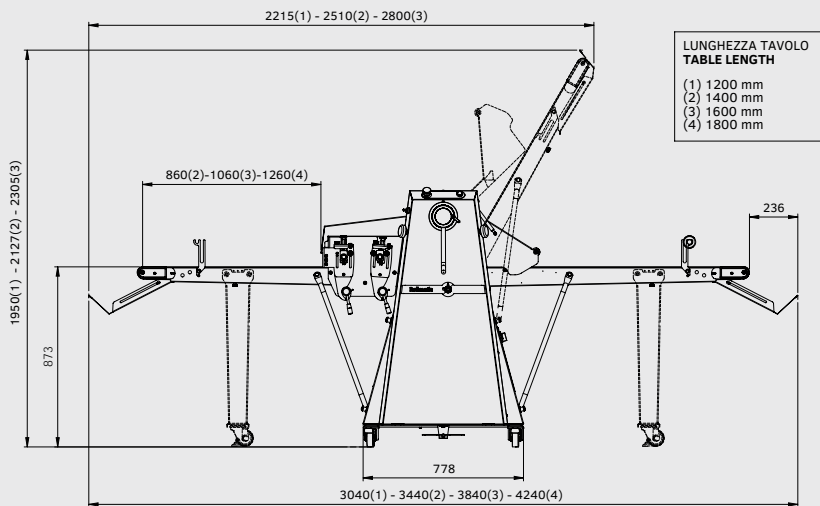

KG 259 Kg

R65S/A/AX

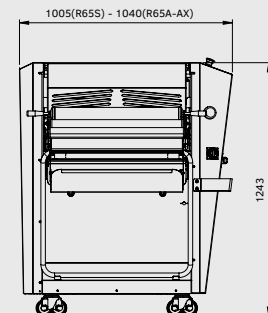
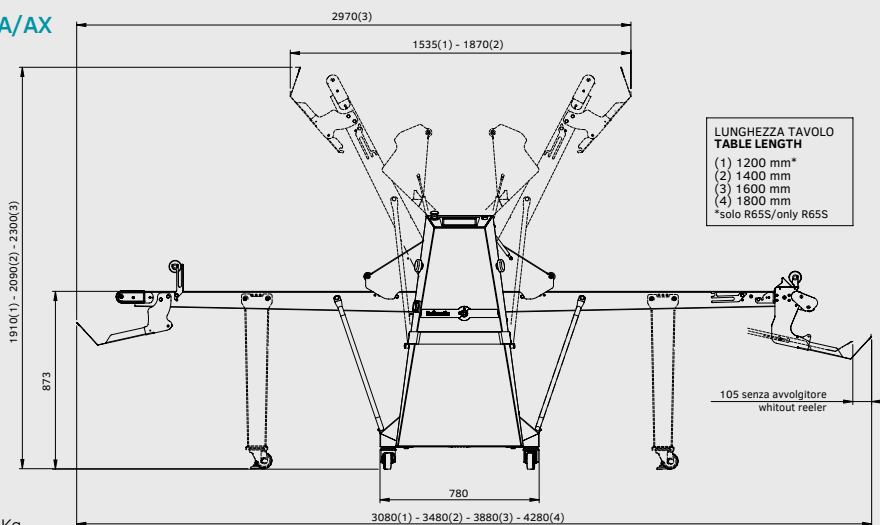

KG 275 Kg