

0.55 Kw

50/60Hz
400V-3 Ph



Sfogliatrice compatta con tavoli ripiegabili. Disponibile in versione da tavolo, con base o carrello. Inversione del ciclo di lavoro con joy-stick e pedaliera (opzione), protezioni cilindri in inox con micro di sicurezza e molla a gas

Compact sheeter with foldable tables. Available in the following models: table-top, with base or trolley. Work cycle inversion with joy-stick and foot control (supplied as option), stainless steel cylinder guards with safety microswitch and gas spring

Laminadora compacta con bancos retráctiles. Disponible en versión para banco, con base o carro. Inversión del ciclo de trabajo con joy-stick y pedales (opción), protecciones de los cilindros de acero inoxidable con microinterruptor de seguridad y resorte de gas

Laminoir compact avec tables pliables. Disponible dans la version laminoir de table, avec base ou chariot. Inversion du cycle de travail par joystick et pédalier (option), protections des cylindres en acier inox avec microinterrupteur de sécurité et ressort à gaz

Компактная тестораскаточная машина со складными рабочими столами. Доступна в версиях: настольная, с основой или тележка. Реверсирование направления движения выполняется посредством джойстика и педали (опция). Защитные покрытия цилиндров (решётки) из нержавеющей стали, оборудованы микровыключателем безопасности и газовой пружиной

Kompakte Tischausrollmaschine mit kippbaren Tischen. Erhältlich als Tischversion, mit Sockel oder Wagen. Umkehr des Arbeitszyklus über Joystick und Fußhebel (Option). Walzenschutzvorrichtung aus Edelstahl mit Sicherheitsschalter und Gasfeder

	R50B	R50
Larghezza cilindri - Roller width	500 mm	
Lunghezza tavolo - Table length	700-800 mm	800-900-1000 mm



Specifiche e accessori / Specifications and accessories

× Standard ○ Optional

	RV50	S5BM	R50B / R50	R55B / R55	R60	R62 / R62-T	R65 / R65-T	R65S / R65S-T	R65A / R65A-T	R65AX / R65AX-T	R65AXP / R65AXP-T
Apertura cilindri (mm) Cylinder opening (mm)	16	38	38	38	50	50	50	50	50	50	60
Trasmissione (C=catena; B=cinghia) Transmission (C=chain; B=belt)	C	C	C	C	C	C	C	C	C	C	B
Inversione ciclo con joystick Joystick cycle reversal		×	×	×							
Inversione ciclo con barra Bar cycle reversal					×						
Inversione ciclo con impulso elettrico Electric cycle reversal						×	×	×			
Inversione ciclo a pedale Foot cycle reversal			○ (R50)	○ (R55)	×	×	×	×			
Tavoli removibili Removable tables				×	×	×	×	×	×	×	×
Sfarinatore automatico Automatic flour duster								○	○	×	×
Avvolgitore automatico Automatic reeler								○ ⁽¹⁾	○	×	×
Regolazione velocità con Inverter Inverter speed regulation			○	○	○	○ ⁽²⁾	○ ⁽²⁾	×	×	×	×
2 velocità 2 speeds					○						
Unità di taglio Cutting unit					○	×	×	×	×	×	
Carrello Trolley			○ ⁽³⁾	○ ⁽³⁾							
Ripiano intermedio con bacinelle Shelf with basins						○ ⁽⁴⁾	○ ⁽⁴⁾	○ ⁽⁴⁾	○ ⁽⁴⁾		
Kit 2 tavoli intermedi con bacinelle Kit 2 intermediate shelves with basins										○	×

(1) Semiautomatico / **Semiautomatic** - (2) Standard su versioni "T" / **Standard on "T" versions** - (3) Solo modelli R50B e R55B / **For R50B and R55B models only** - (4) Con alcune limitazioni / **With some limitations**



RV50

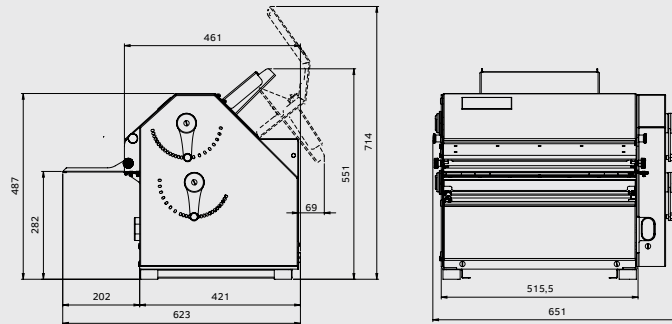

 85 Kg

S5BM

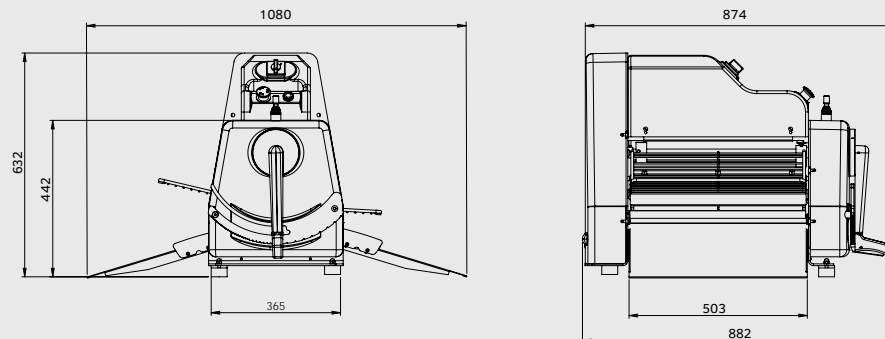

 81 Kg

R50B

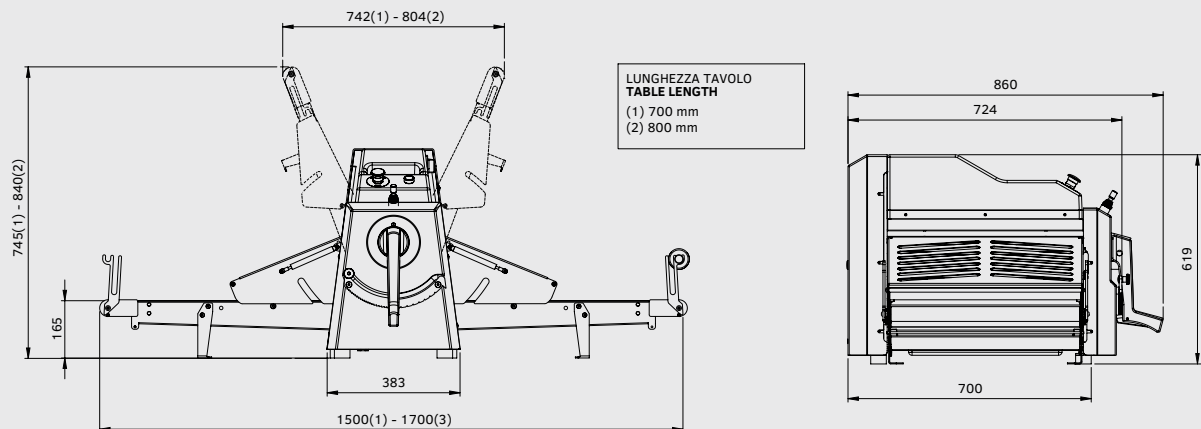

 91 ÷ 120 Kg

Dimensioni / Dimensions

KG Peso netto / Net weight

R50

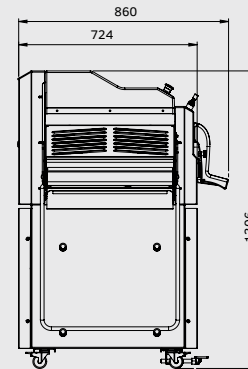
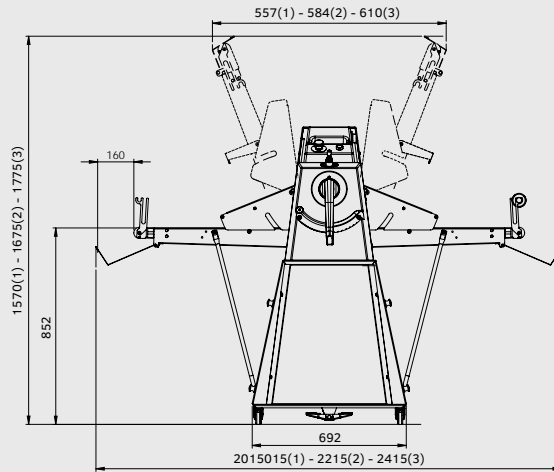

**LUNGHEZZA TAVOLO
TABLE LENGTH**
(1) 800 mm
(2) 900 mm
(3) 1000 mm

KG 150 ÷ 219 Kg

R55B

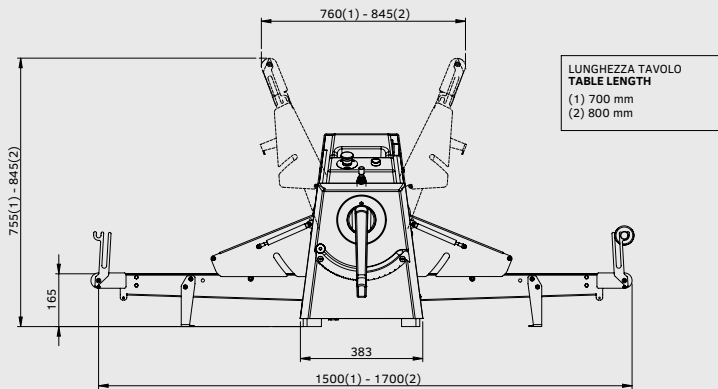

**LUNGHEZZA TAVOLO
TABLE LENGTH**
(1) 700 mm
(2) 800 mm

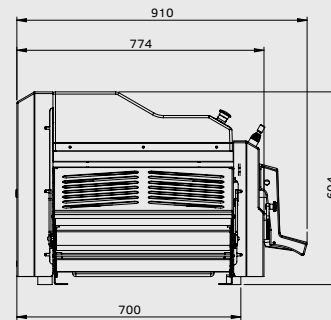

KG 91 ÷ 120 Kg

R55

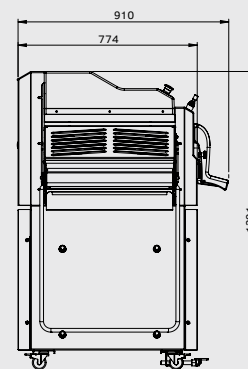
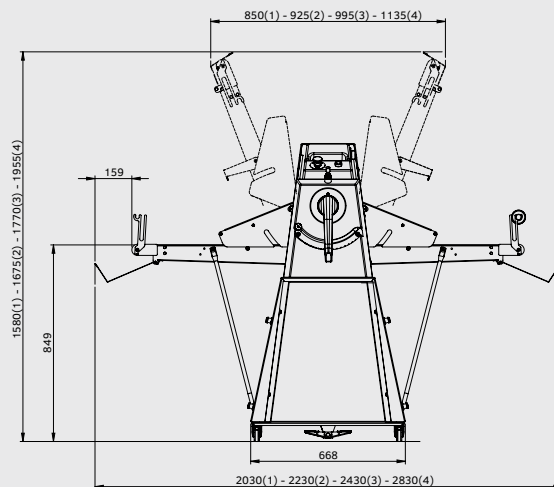

**LUNGHEZZA TAVOLO
TABLE LENGTH**
(1) 800 mm
(2) 900 mm
(3) 1000 mm
(4) 1200 mm

KG 150 ÷ 219 Kg